

The Production of High Centrifugal Fields

J. W. Beams, J. L. Young, and J. W. Moore

Citation: *Journal of Applied Physics* **17**, 886 (1946); doi: 10.1063/1.1707658

View online: <https://doi.org/10.1063/1.1707658>

View Table of Contents: <http://aip.scitation.org/toc/jap/17/11>

Published by the *American Institute of Physics*

Articles you may be interested in

[Spinning Rotor Pressure Gauge](#)

Review of Scientific Instruments **33**, 151 (1962); 10.1063/1.1746520

[A Simple and Dependable Electrical Feedthrough for High Pressures](#)

Review of Scientific Instruments **41**, 1896 (1970); 10.1063/1.1684448

[A Fringe Counting Laser Interferometer Manometer](#)

Review of Scientific Instruments **44**, 180 (1973); 10.1063/1.1686077

[Nonuniform Emission of Thermionic Cathodes](#)

Journal of Applied Physics **37**, 2234 (1966); 10.1063/1.1708793

[A Mass Spectrometer without Memory Effect for Gas Analysis in Ultrahigh Vacuum](#)

Journal of Vacuum Science and Technology **6**, 93 (1969); 10.1116/1.1492633

[Calibration to High Precision in the Medium Vacuum Range with Stable Environments and Micromanometer](#)

Journal of Vacuum Science and Technology **6**, 401 (1969); 10.1116/1.1492701

Ultra High Performance SDD Detectors

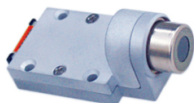
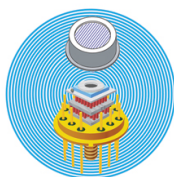

See all our XRF Solutions

on fused silicon indicates that the high resistance values and high temperature coefficients of resistance observed in the films deposited on porcelain are caused by the very high purity of the silicon and not by the crystal size nor by intergranular films. The close agreement between the activation energies obtained from the photoelectric, thermal-conductance, and optical data

suggests the phenomena have a common origin—electron transitions from the upper filled band to the conducting band.

Acknowledgment: We are very grateful to Mr. E. F. Kingsbury for assistance in determining the sensitivity of some of the cells and in making observations on the optical absorption of silicon.

The Production of High Centrifugal Fields*

J. W. BEAMS, J. L. YOUNG, III, AND J. W. MOORE

Rouss Physical Laboratory, University of Virginia, Charlottesville, Virginia

(Received July 15, 1946)

High centrifugal fields were produced by spinning small solid steel spherical rotors up to their bursting speeds. The rotors were supported magnetically in a vacuum by an improved method and spun by rotating magnetic fields. The peripheral velocities at which the rotors of various sizes, made of the same (flaw free) steel and having the same shapes, exploded, were roughly the same and of the order of 10^5 cm/sec. A centrifugal field of 2.4×10^8 times gravity was obtained with a .795-mm spherical rotor which was the smallest diameter tried. Calculations indicate that in some cases plastic flow probably occurred in small regions near the centers of the spherical rotors somewhat below their bursting speed.

WHEN substances are placed in a centrifugal field two general types of phenomena may occur. The first type depends upon $(2\pi N)^2 r^2 = v^2$ where N is the number of revolutions per sec., r is the radius of the rotor, and v is the peripheral speed or upon the energy difference between axis and periphery. The second type depends upon $(2\pi N)^2 r$ or the intensity of the centrifugal field. In this paper a method is given for producing very high centrifugal fields for use in the study of the second type of phenomena.

In a spinning homogenous elastic rotor the maximum stress produced is proportional to $(2\pi N)^2 r^2$ or the square of the peripheral speed.¹ That is, similarly shaped rotors made of the same material will explode when their peripheral velocities are approximately equal. Consequently for the production of the highest centrifugal fields which depend upon $(2\pi N)^2 r$ the radius of the rotor must be as small as possible.

For rotors made of a given elastic material the highest peripheral speed should be obtained when the shape is such that the radial and

tangential stresses are of constant value throughout the rotor.¹ If hardened high strength steel is used for the rotor, some considerable pains are

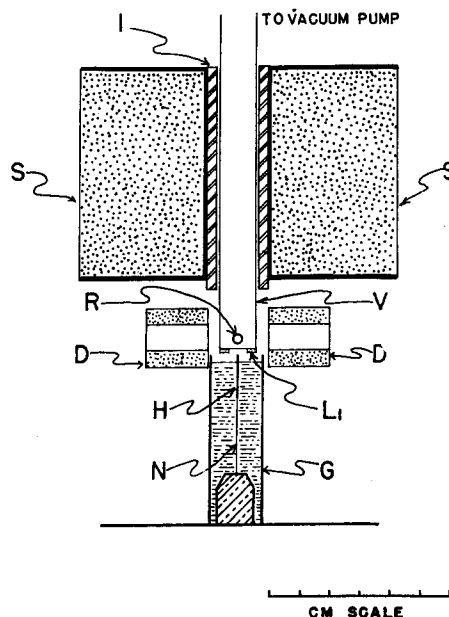

FIG. 1.

* The work described in this paper has been supported by the Bureau of Ordnance, U. S. Navy under Contract NOrd-7873.

¹ Stodola, *Steam and Gas Turbines* (McGraw-Hill Book Company, Inc., New York), Vol. I, p. 376.

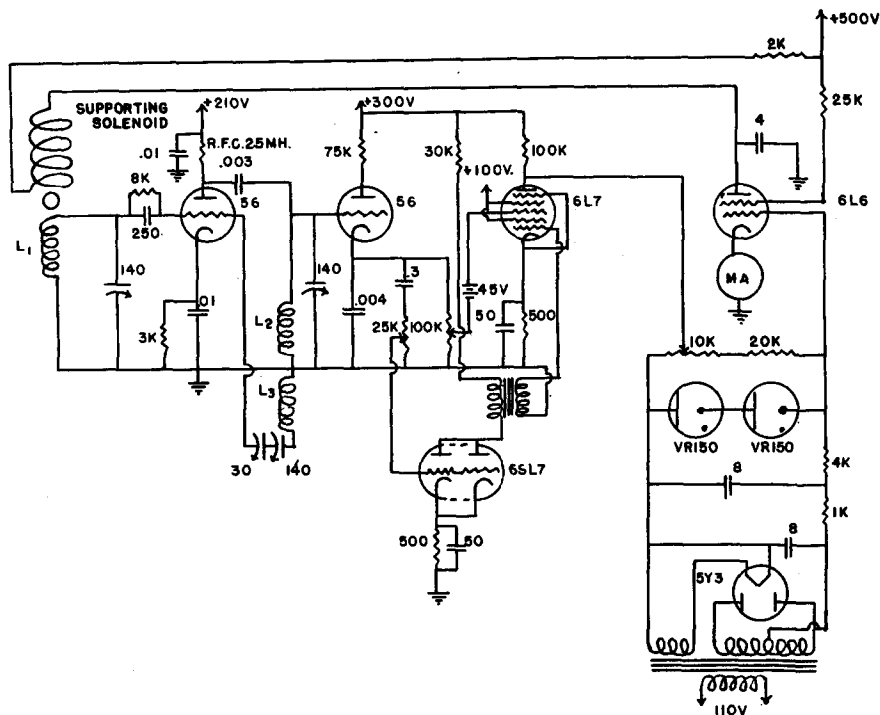

FIG. 2.

required to grind the rotor to the shape required by the above condition. However, spherical rotors are commercially available in the form of high strength solid steel balls for use in ball bearings. Consequently, these approximately spherical rotors were used in the experiments. Also in addition to their availability the calculated critical vibration frequencies of these spherical rotors are well above their bursting speeds.²

EXPERIMENTAL ARRANGEMENT

The rotors were spun by the general method developed at Virginia by a number of different workers³⁻⁶ for spinning small rotors. However, in the present experiments, considerable improvements in the apparatus have been made. Figure 1 shows schematically the arrangement used. The rotor *R* is suspended in the axial magnetic field of the solenoid *S* and is spun by a two phase rotating magnetic field in the two

pairs of coils *D*. The horizontal position of the steel rotor is maintained by the symmetrically diverging field of the solenoid while its vertical position is maintained by an automatic regulation of the current through the solenoid *S*. The small coil *L*₁ is part of the grid circuit of a tuned grid tuned plate radiofrequency oscillator (Fig. 2) which regulates the current through *S*. It is so arranged that when the rotor rises the current through *S* decreases. These current changes are such as to position accurately the rotor without observable hunting. An iron tube *I* with $\frac{3}{4}$ " O. D. $\frac{3}{32}$ " wall thickness and $3\frac{3}{8}$ " long was placed inside the solenoid to increase the field at *R*. A small iron wire *H* mounted in a glass tube *G* filled with a liquid assisted in damping any horizontal motion of the rotor. The glass chamber *V* surrounding the rotor *R* was evacuated by the usual fore pump, diffusion pump cold trap combination. The pressure surrounding the rotor was measured by an ionization gauge.

SUPPORTING CIRCUIT

The circuit used for supporting the rotors is shown in Fig. 2. It will be observed that the

² Love, *Mathematical Theory of Elasticity* (Dover Publications, New York), fourth edition, p. 285.

³ F. T. Holmes, *Rev. Sci. Inst.* **8**, 444 (1937).

⁴ F. T. Holmes and J. W. Beams, *Nature* **140**, 30 (1937).

⁵ C. S. Smith, *Rev. Sci. Inst.* **12**, 15 (1941).

⁶ L. E. MacHattie, *Rev. Sci. Inst.* **12**, 429 (1941).

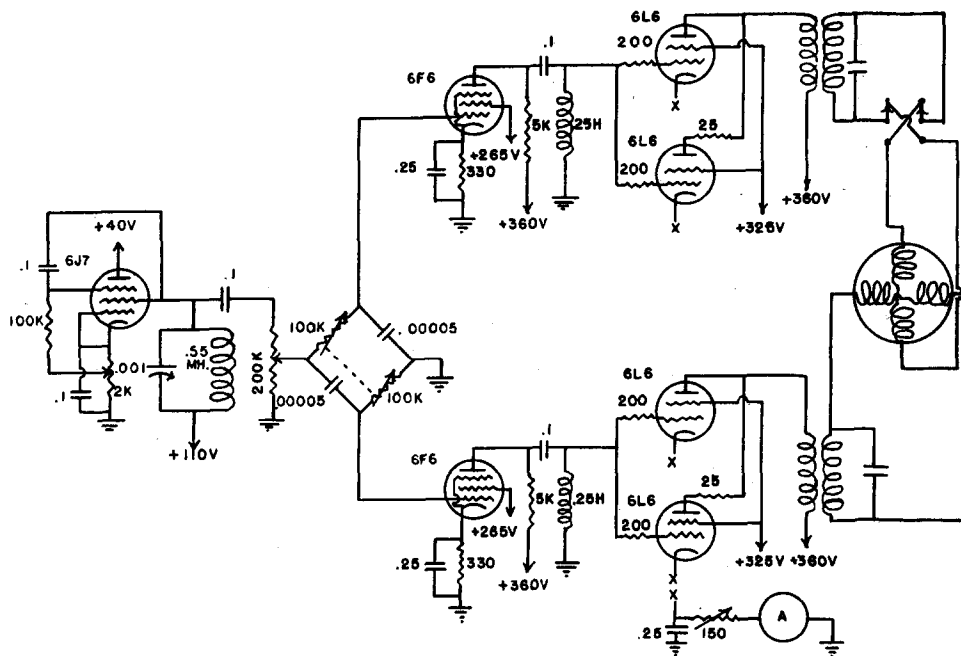

FIG. 3.

"pick-up" coil L_1 is in the grid circuit of the partially neutralized tuned grid tuned plate radiofrequency (10 megacycles which is large in comparison with the rotor speed) oscillator. The effective "Q" of the grid circuit is critically changed by small variations in the height of the rotor R . This change is produced by the reflected impedance due to induced eddy currents in the rotor and to the very slight change in inductance and capacity of the coil L_1 . Consider a virtual downward displacement of the rotor. This will reduce the amplitude of oscillation in the grid circuit and, since the oscillator is partially neutralized, the amplitude of oscillation in the plate circuit will also decrease. As a result the potential across the "cathode follower" will likewise drop and cause a lower potential or so-called "error" signal to be applied to the "error" grid of the 6L7 mixer tube. The plate potential of the 6L7 mixer tube will then increase which, in turn, raises the potential on the control grid of the 6L6 power tube. This causes an increase in current through the supporting solenoid which increases the lifting force on the rotor and restores it to its original position. With this arrangement alone small vertical oscillations or hunting of the rotor occurs so addi-

tional electrical "damping" was introduced into the circuit. This "damping" is obtained by mixing the amplified derivative of the "error" signal with the "error" signal in the 6L7 mixer tube. The derivative of the "error" signal is obtained from the capacity-resistance circuit in parallel across the cathode follower as shown in Fig. 2. The magnitude of the capacity and of the resistance in this circuit was obtained by observing the hunting frequency of the rotor and then making the capacitive reactance and resistance such that the derivative signal would not be too small and at the same time more than 80° out of phase with the variation of the "error" voltage. The values are given in Fig. 2. This derivative signal is amplified by the two triodes of a 6SL7 in parallel and applied through transformer coupling to the second control grid of the 6L7 mixer tube. This arrangement greatly stabilized the rotor and reduced all vertical hunting and oscillations to such an extent that no vertical motion of the rotor could be observed with a 20-power microscope focused on markings of the rotor. The values of the resistances, capacities and inductances are given in Fig. 2. The supporting solenoid S was wound with 20,500 turns of No. 30 wire. Its inside diameter

was $\frac{13}{16}$ " and its length $2\frac{5}{8}$ ". The coil L_1 was flat wound with 12 turns of No. 32 copper wire. Its effective diameter was about 1.26 cm. L_2 was 2 cm long, 4.3 cm in diameter, and contained 9 turns of No. 14 copper wire. L_3 contained 9 turns of No. 28 copper wire close wound next to the low end of L_2 .

DRIVING CIRCUIT

The driving circuit which produces the rotating magnetic field in the coils D which in turn spins the rotor is essentially the same as that used by MacHattie.⁶ The 4 coils D are mounted symmetrically around the rotor and opposite pairs are connected in series. The currents in the two pairs of coils differ in phase by approximately 90° and are tuned to the driving frequency by shunting condensers. Figure 3 shows a diagram of the circuit. The output of the transition oscillator is passed through a volume control and then a phase splitting bridge. Each of the phases is amplified and applied to the coils so that the currents in the coils D are 90° out of phase. The frequency used varied from 100,000 cycles per sec. for accelerating the $\frac{5}{32}$ " (3.97 mm) rotor to 500,000 cycles/sec. for accelerating the $\frac{1}{32}$ " (.795 mm) rotor. The constants given in Fig. 3 were those used to accelerate the $\frac{1}{16}$ " (1.59 mm) rotor. It will be observed that the solid steel rotor is actually the armature in an induction motor. In starting the so-called "slip" is very high and gradually decreases as the rotor speeds up. However, the torque at high "slips" gives good acceleration because of the comparative high resistance of the rotor. For example, with the $\frac{1}{16}$ " rotor the acceleration was roughly 30 rev./sec.² with approximately $7\frac{1}{2}$ watts input to the coils D . During some of the experiments the coils D were cooled by a small electric fan.

MEASUREMENT OF ROTOR SPEED

At first some difficulty was experienced in getting a simple accurate method of measuring the rotor speed, but the problem was successfully solved by the apparatus shown schematically in Fig. 4. One-half of the rotor is polished and the other half darkened by dipping in dilute H_2SO_4 which had been in contact with metallic antimony. This dark layer is very thin and is not destroyed by the highest centrifugal force so

far obtained. Light from an incandescent lamp A is focused on the rotor R and the resulting scattered light focused on the electron multiplier photo-cell P (931A). The variable output from the photo-cell, due to the spin of the rotor, is amplified and fed to one pair of plates of a cathode-ray oscillograph. This frequency of the rotor is then compared in the usual way with the frequency of sweep applied to the other pair of plates of the oscillograph. This sweep frequency was calibrated by a standard frequency oscillator (accuracy from .1 to .01 percent) up to 50,000 cycles per sec. Above this frequency multiples of the calibrated frequencies are used. It is believed that the rotor speeds are precise to three significant figures.

While the above frequency measurements were precise enough for the present experiments, it is highly desirable to have better precision for deceleration measurements. Accordingly, the output of the photo-cell was made to actuate an ordinary scale of 64 counter circuit in such a way that the counter counts the number of r.p.s. directly. This method gives high precision but the present arrangement is not suited for counting above 5×10^4 r.p.s., even with a counter clock, especially wound for the purpose. However, it is hoped to extend its range on up to much higher values.

EXPERIMENTAL RESULTS

As mentioned before the rotors were solid steel spheres (ball bearings). In order to determine the axis of rotation a small flat was ground on each of the rotors. This varied from 1 mil for the $\frac{1}{32}$ "

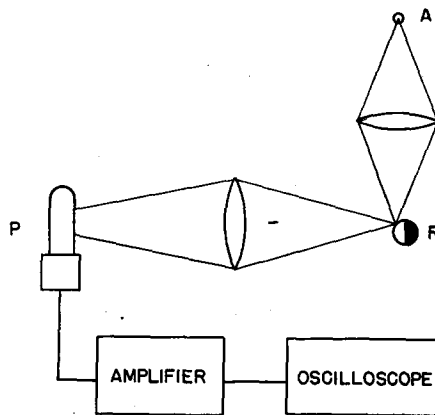

FIG. 4.

TABLE I.

Diam. of rotor mm	Rotor speed r.p.s.	Peripheral speed cm/sec.	Centrifugal acceleration times gravity	Maximum calculated stress lb./in. ²
3.97	77,000	9.60×10^4	4.71×10^7	410,000
2.38	123,500	9.25×10^4	7.20×10^7	385,000
1.59	211,000	1.05×10^5	1.43×10^8	498,000
.795	386,000	9.65×10^4	2.40×10^8	420,000

rotor to 5 mils for the $\frac{5}{32}$ " rotor. This small flat surface became the top of the rotor and hence determined the vertical axis of rotation perpendicular to its surface. The size of the small damping needle H (Fig. 1) together with the viscosity of the liquid surrounding it is determined by the size of the rotor. For a $\frac{1}{16}$ " rotor H was 8 mils and $\frac{1}{2}$ " long, N was 4 mils and $1\frac{1}{2}$ " long and the liquid was "three in one" oil. When the adjustments are properly made no variation in the position of the rotor can be observed. The rotor, the glass vacuum chamber, and the driving coils are surrounded by a wooden barricade which stops the flying parts of the exploding rotor. Although the rotors used were grade A commercial steel ball bearings and supposedly free from flaws, a number of them exploded at abnormally low rotor speeds. These rotors showed definite flaws when their parts were examined after an explosion. However, most of the rotors required very high stresses to explode them. Table I gives some of the results obtained just before the rotors exploded.

It will be observed that the maximum peripheral speed for all of the rotors is approximately 10^5 cm/sec. and determines the bursting speed for the steel used. In accordance with expectations the maximum centrifugal field was obtained with the smallest rotor used and for the .795-mm rotor was 240 million times gravity. In the fifth column are tabulated the maximum stresses in the rotors calculated by the method of Chree.⁷ In the calculations it is assumed that the rotors are perfectly elastic. The calculations show that the stresses reach a maximum at the center of the rotor and fall off toward the surface. Actually

⁷ C. Chree, Proc. Roy. Soc. 58, 39 (1895).

the steel is well known to be plastic and it is probably that the material in a small region around the center of the rotor flows and relieves the stresses. Therefore, the calculated stresses are probably well above those actually occurring.

The air pressure surrounding the rotor as measured by an ionization gauge was maintained between 10^{-5} and 2×10^{-5} mm of Hg. The "air" friction on the spherical rotor would produce a deceleration, when the rotor is spinning freely with the driving power off, given approximately by

$$\log_e \frac{N}{N_0} = \frac{-5p}{rd} \left(\frac{M}{2\pi RT} \right)^{\frac{1}{2}} (t - t_0),$$

where N_0 is the number of r.p.s. at time t_0 ; N is the number of r.p.s. at time t ; p is the gas pressure in bars, d is the density of the steel = 7.8 g/cm³, T = absolute temperature; R = gas constant, M = molecular weight of the gas, and r = radius of the spherical rotor. With the 1.59-mm rotor spinning freely at about 120,000 r.p.s. with a pressure of about 10^{-5} mm Hg it required roughly two hours to lose one percent of its speed. Therefore, the order of magnitude of this deceleration can be accounted for by gas friction on the rotor. No doubt the rotors are slightly non-homogeneous magnetically and the supporting field is perhaps not strictly symmetrical. Also, in addition, other small factors such as oscillations in the pick-up coil probably add up to give a small residual drag. However, in practice, since the major portion of the drag apparently is due to gas friction, the deceleration can be made very small. With proper coupling between a rotating magnetic field driven by a piezoelectrically controlled oscillator an almost constant speed rotor should be obtained. Consequently many experiments requiring constant rotor speed as well as high centrifugal fields are made possible.

We are much indebted to Drs. L. G. Hoxton and F. Bader for checking some of our calculations.